

User Manual

DS808A

4 Channel Incandescent /Fluorescent Dimmer Pack

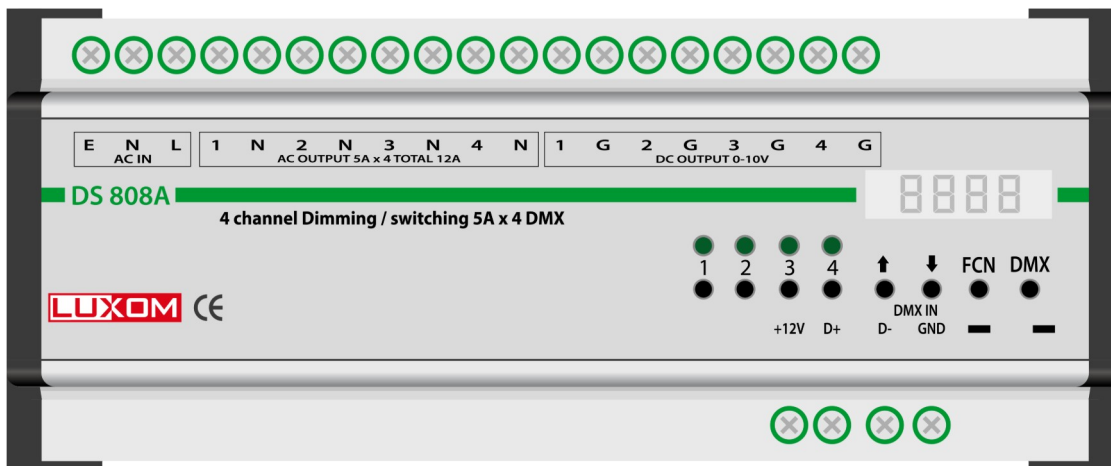

INDEX

1 INTRODUCTIONS	3
1-0 BEFORE INSTALLATION	3
1-1 FEATURES	3
1-2 SPECIFICATIONS	3
1-3 PANEL INTRODUCTIONS.....	4
1-4 WIRING DIAGRAM.....	5
2 OPERATIONS	6
2-1 INITIALIZATION.....	6
2-2 DMX IN FUNCTION	6
2-3 OUTPUT MODE SETTING	7
2-4 AC OUTPUT OFF DELAY SETTING	8
2-5 CHANNEL OUTPUT CHECK	8
2-6 DMX-512 INPUT BYPASS.....	9
3 EDX SYSTEM	10
3-0 EDX MODE	10
3-1 ID NUMBER SETTING	12
3-2 ZONE SETTING	12
3-3 SCENE FADE TIME SETTING	13
3-4 EDIT DIMMING LEVEL OF EACH CHANNEL	14
3-5 SCENE SAVE	14
3-6 SCENE OVERLAP FUNCTION	15
3-7 CURRENT DETECT FUNCTION.....	15
3-8 QUICK TURN ON/OFF CHANNELS.....	16
3-9 PARTITION (MULTI-ZONE) FUNCTION	16
APPENDIX 1 AUTO OFF TABLE	18
APPENDIX 2: FADER TIME TABLE	19

1 Introductions

1-0 Before Installation

1. Please set proper mode for the loads before turning on the power. The non-dimming lamp may be damaged by setting as dimming mode.
2. Working environment:
Temperature: 0°C - 40°C
Humidity: 20% - 80%

1-1 Features

1. Dimmable for conventional lamps (leading-edge) and 0-10V DC fluorescent ballast or LED transformers
2. 6 scenes with fade effect.
3. Up to 99 zones

1-2 Specifications

1. Power Input: 100 - 240V AC
2. Power Consumption: 7W
3. Protocol: DMX-512, EDX
4. Dimming Control: Leading edge (forward phase) dimmable, 0-10V DC
5. Output: 5A per channel. Total 12A max.
6. DC Output on EDX Port: 200mA.
7. Dimension: 190mm(W) x 88mm(H) x 57mm(D)
8. Weight: 590g

1-3 Panel Introductions

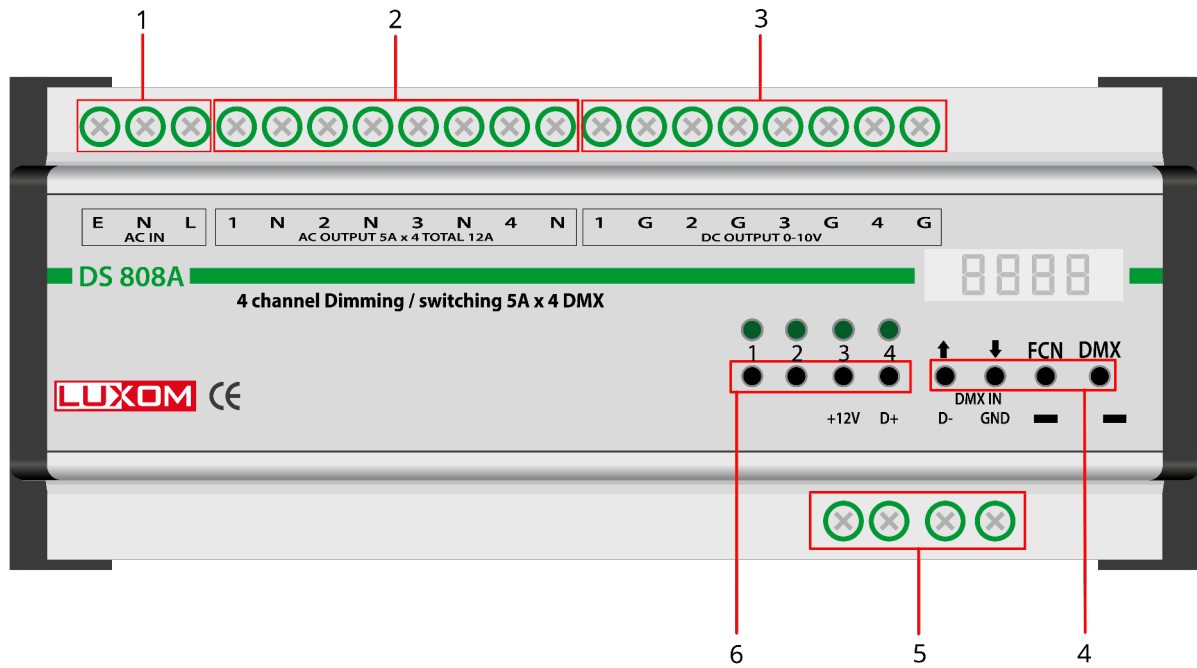

1. AC 100 – 240V Input
2. AC Output x 4
3. DC 0 – 10V Output x 4
4. DMX-512/ EDX Connector
5. DMX/EDX connector
6. Instant Output Key **【1】 【2】 【3】 【4】**

1-4 Wiring Diagram

1-4-1 Dimmable or Non-dimmable Lamps Wiring

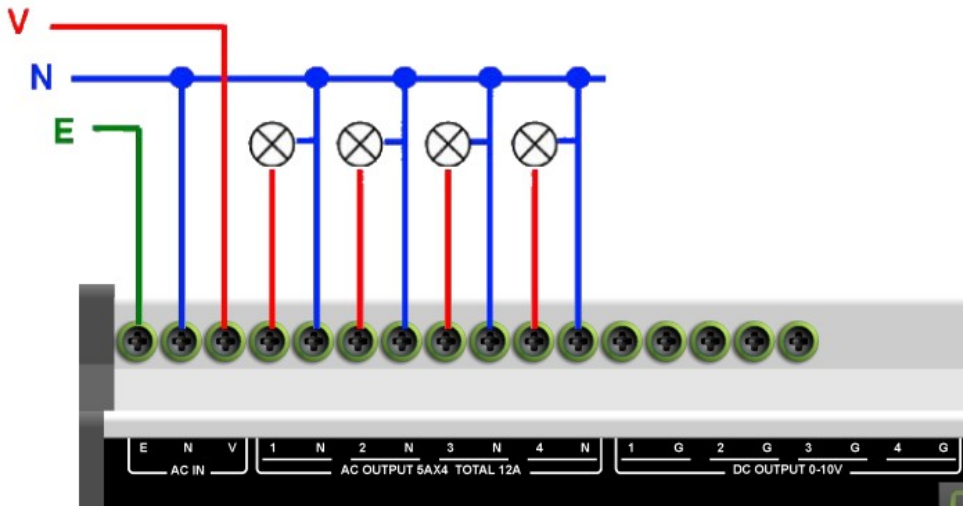

* Set the channel connected to dimmable lamps as dimming mode; set the channel connected to non-dimmable lamps as switching mode.

1-4-2 1-10V Dimmable Fluorescent Ballast Wiring

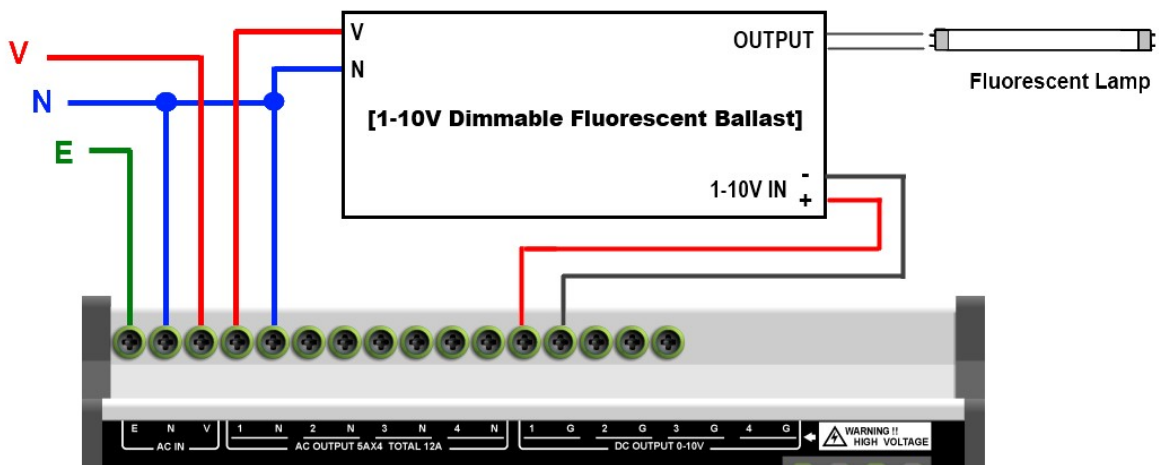

* Set the channel connected to 1-10V dimmable fluorescent ballast (or 0-10V dimmable transformers) as fluorescent mode

2 Operations

2-1 Initialization

STEP-1: Press **【▲】** and **【▼】** at the same time then switch on the device , LED displays,



STEP-2: Press **【FCN】** to cancel memory Initialization , LED displays,



STEP-3: Press **【DMX】** to start memory Initialization , LED displays,



Then displays,



OR



2-2 DMX In Function

STEP-1: Hold **【DMX】** and then press **【▲】** or **【▼】** to set the DMX IN start channel address. For example, press **【▲】** , LED displays,



In the DMX IN mode, the first dot is blinking means the DMX signal inputs.



2-3 Output Mode Setting

DS808A can control normal dimming lamp, non-dimming lamp and DC dimming fluorescent lamp. Please make sure select right output mode to avoid the damage of the lamps.

STEP-1: Hold **【FCN】** until LED displays,



AL: It means all channels.

F: It means **0 – 10VDC mode (0-10V DC fluorescent lamps)**.

STEP-2: Press **【▲】** or **【▼】** to choose all channel's output mode .



S: It means **switching (SWITCH)**

d: It means **dimming (DIMMER)**

STEP-3: If you would like to set the output mode for individual channel, press **【FCN】** to choose a channel then press **【▲】** or **【▼】** to choose output mode.

STEP-4: Press **【DMX】** to save the setting and exit.

1. When a channel is set as SWITCH mode: when its input signal lower than 20% , AC output will be turn off ; when its input signal higher than 50% , AC output will be turn on.
2. When a channel is set as control fluorescent lamp: DC OUTPUT is DC 0V ~ 10V, AC OUTPUT is ON and OFF. When input signal is higher than 10% (1AH) AC OUTPUT will be turn on.

2-4 AC Output Off Delay Setting

STEP-1: Press **【FCN】** until LED displays,



01 means that AC OUT OFF delay time is set as 1 second.

When the output is higher than 10% (1AH), AC OUT will be turn on.

When the output is lower than 8% (13H), AC OUT will be turn off after the delay time.

STEP-2: Press **【▲】** or **【▼】** to adjust AC OUT OFF delay time . For example, press

【▲】 , LED displays,



Now, the delay time of AC OUT OFF is set as 2 seconds.

STEP-3: Press **【DMX】** to save the setting and exit.

Please refer appendix 1 for AC Output Off Delay Time Table

2-5 Channel Output Check

STEP-1 On the main page, press **【▲】** or **【▼】** , LED displays,



DS808A is in the mode of auto channel Output check. Now, it means that channel 1's output level is 37%.

STEP-2 When channel 2's output is changing; DS808A will automatically convert to display channel 2's output level.



STEP-3 Press **【▲】** or **【▼】** again, you can choose the channel you want to check. For example, choose channel 3, LED displays,



Afterwards, auto channel output check function will be closed.

STEP-4 Press **【DMX】** to exit.

2-6 DMX-512 Input Bypass

STEP-1: On the main page, hold **【FCN】** till LED displays,



d-OF means DS808A can be controlled by DMX-512 signal.

STEP-2: Then press **【▲】** to shift to bypass DMX signal, LED displays,

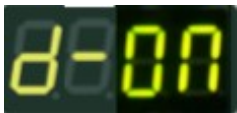

d-ON means DS808A bypass DMX signal. (Press **【▼】** again to shift to d-OF again.)

STEP-3: Press **【DMX】** to save the setting and exit.

3 EDX System

DS808A can work either in DMX-512 mode or EDX mode.

DMX-512 Mode: DS808A can be controlled by DMX-512 controllers.

EDX Mode: DS808A can be recalled its stored lighting scenes by connecting to ECP scene control panels.

3-0 EDX Mode

EDX is a protocol specifically designed for architectural and environmental lighting applications. EDX dimmers or devices are able to store scenes in themselves.

Each EDX device or ECP panel can be specified by a zone number. The scenes stored in EDX devices can be recalled by ECP panels with the same zone number.

For example, EDX devices configured as zone 1 can be controlled (recall scenes) by ECP panel configure as zone 1.

EDX devices configured as zone 5 can be controlled (recall scenes) by ECP panel configure as zone 5.

Figure 1: One EDX device with one ECP scene panel

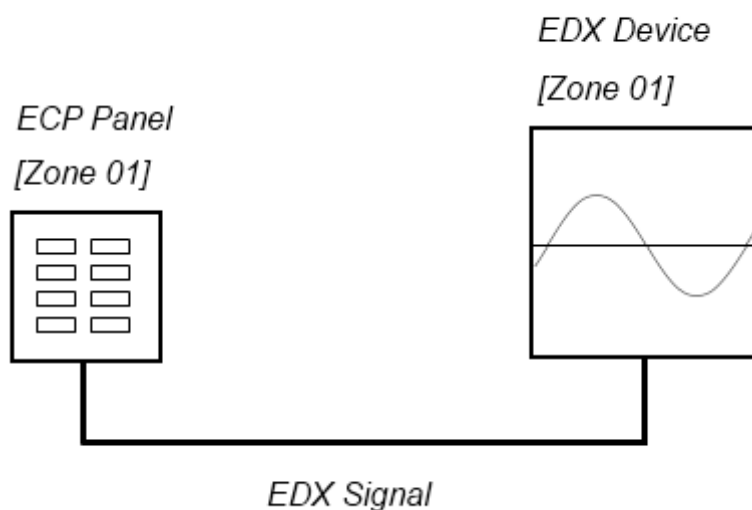
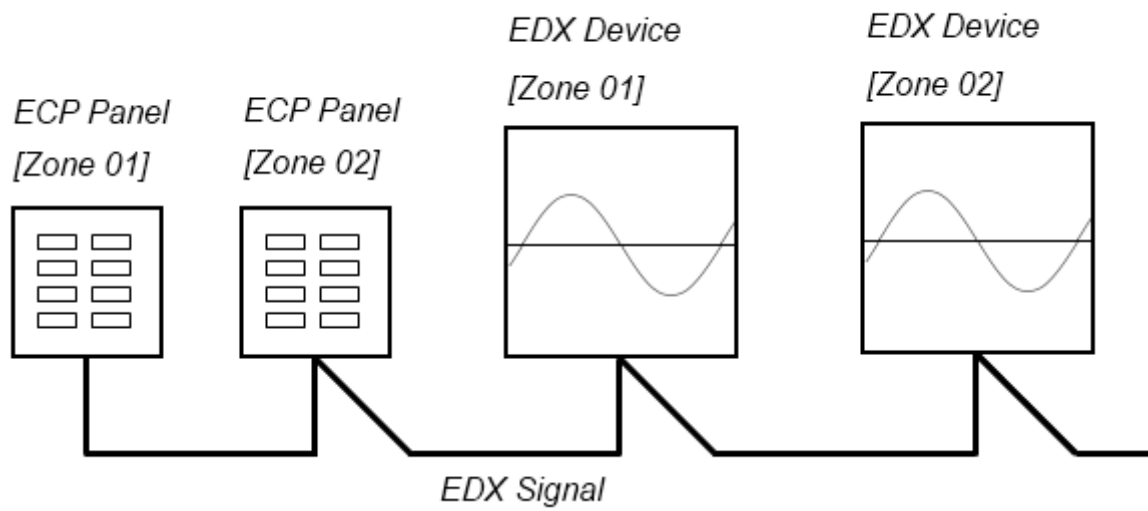

Figure 2: Multiple EDX devices with ECP scene panels



ECP scene panel 1 controls EDX device 1.

ECP scene panel 2 controls EDX device 2.

* If there are both DMX-512 and EDX signal present, DMX-512 signal has the highest priority.

3-1 ID Number Setting

Working in EDX system, DS808A needs to set ID number and zone number. The default setting of DS808A's ID number is 001.

When one device's working alone, there is no need to set the ID number, but when several devices' working together, each device must have a different ID number.

STEP-1: Hold **【FCN】** in any mode until LED displays,



STEP-2: Then press **【▲】** or **【▼】** to adjust ID number, after setting, press **【DMX】** to display the DMX start channel address.

STEP-3: Press **【DMX】** to save the setting and exit.

3-2 Zone Setting

Zone definition : User must set zone code of the device in EDX system. This code has two parts. The first part is zone number, and the second is starting channel address. For example, if there are 4 DS808A in zone 1 with total 16 channels, the zone code should be set as 01-01, 01-05, 01-09, and 01-13.

STEP-1: On the main page, hold **【FCN】** till LED displays,



The last 2 digits 01 are blinking; these 2 digits mean "starting channel address".

STEP-2: Press **【▲】** or **【▼】** to adjust start channel address. For example , press **【▲】** , LED displays,



STEP-3: Press **【FCN】** shift to adjust zone value, LED displays,



The first 2 digits 01 are blinking; these 2 digits mean zone number.

STEP-4: Press **▲** or **▼** to adjust zone number. For example, press **▲** , LED displays :



STEP-5: Press **DMX** to save the setting and exit.

3-3 Scene Fade Time Setting

STEP-1: In the AC OUT OFF delay setting mode , hold **FCN** till LED displays,



0 F 0.1 means that scene OFF's delay time is 0.1 second.

The first digit means scene name: "0" means OFF scene, "1" means Scene 1 , "2" means Scene 2 and so on ..
0.1 means fade time.

STEP-2: Press **FCN** to choose the scene number. For example, when LED displays 0 F 0.1, press **FCN** to choose scene 1.



STEP-3: Press **▲** or **▼** to adjust the value . For example , press **▲**

LED displays,



STEP-4: Press **DMX** to save the setting and exit.

Please refer appendix 2 for fader time table.

3-4 Edit Dimming Level of Each Channel

STEP-1: Press【 **DMX** 】 to return to main screen.

STEP-2: Press【 **▲** 】 or 【 **▼** 】 , LED shows



The left two digits (01) mean channel 1; the right two digits mean dimming level.

STEP-3: Press【 **▲** 】 or 【 **▼** 】 to set dimming level of channel 1 or press 【 **FCN** 】 to select channel 2 to channel 4.

STEP-4 Press 【 **DMX** 】 to exit.

3-5 Scene Save

STEP-1: Edit a scene by the steps shows in 3-4 or any DMX controller and then cut off the DMX signal.

STEP-2: Press【 **DMX** 】 and【 **1** 】 to save the current output to scene 1, LED displays,



How to save other scenes:

SCENE 2 → 【 **DMX** 】+ 【 **2** 】

SCENE 3 → 【 **DMX** 】+ 【 **3** 】

SCENE 4 → 【 **DMX** 】+ 【 **4** 】

SCENE 5 → 【 **DMX** 】+ 【 **FCN** 】+ 【 **1** 】

SCENE 6 → 【 **DMX** 】+ 【 **FCN** 】+ 【 **2** 】

3-6 Scene Overlap Function

Usually, when the user recall a scene, the previous scene will be replaced. This function is for overlap SC5 or SC6 on another scene. If you recall one scene out of SC1-4 first, then recall SC5 or SC6, the later one (SC5 or SC6) will overlap to the previous one (SC1-4), so user will see two scenes at the same time.

If there is any channel that is in both scenes, it will output at the higher dimming value.

For example,

Overlap SC5 to SC4,

If CH1's dimming value in SC4 is 40% and in SC5 is 20%, it will remain 40%;

If CH1's dimming value in SC4 is 40% and in SC5 is 85%, it will change to 85%.

STEP-1: On the main page, hold **【FCN】** till LED displays.



ON: turn on scene overlap function.

OFF: turn off scene overlap function.

STEP-2: Press **【▲】** or **【▼】** to shift between on and off. After setting, press **【DMX】** to save and exit.

STEP-3: Press **【DMX】** to save the setting and exit.

3-7 Current Detect Function

STEP-1: On the main page, hold **【FCN】** till LED displays.



0.0 means current is 0A now.

When DS808A's output current over 22A, it will automatically curb the output below 20A;

When it's output current over 30A, it will be turned off automatically.

STEP-2: Press **【DMX】** to exit.

3-8 Quick Turn On/Off Channels

When no DMX signal inputs, press **[1] ~ [4]** to quick turn on/off 1-4 channel.

3-9 Partition (Multi-Zone) Function

Generally, all channels on DS808A can be set to only 1 zone(Please refer 3-2). To make DS808A more flexible, you can assign each channel on DS808A to different zones by using partitioning function. For example, you assign channel 1 – 2 on DS808A to partition 1 and channel 3 – 4 on DS808A to partition 2. There are 2 control panels (ECP-106) connected to DS808A, one is set to zone 1; the other is set to zone 2. If scenes are recalled by ECP-106 of zone 1, only channel 1 – 2 on DS808A will change their dimming levels. If scenes are recalled by ECP-106 of zone 2, only channel 3-4 on DS808A will change their dimming levels.

Figure: Channel 1 and 2 on EDX/EPX device in zone 1 (channel 1,2 are controlled by ECP panel in zone 1)

Channel 3 and 4 on EDX/EPX devices in zone 2 (channel 3,4 are controlled by ECP panel in zone 2)

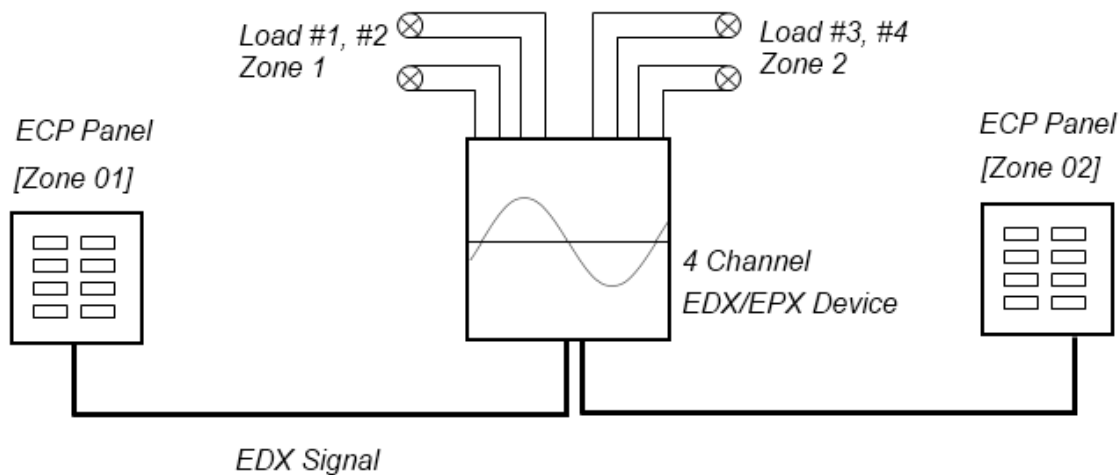

STEP-1: Hold **[FCN]** till LED displays,



It means partition (multi-zone) function is off.

Press **【▲】** or **【▼】** to turn on/off partition function.



STEP-2 Press **【FCN】** again, LED shows



It means that channel 1 is in zone 2.

Press **【▲】** or **【▼】** to set channel 1 to zone 1 - 8.

STEP-3: Press **【FCN】** to select other channels. Follow step-2 to set zone numbers of other channels.

STEP-4: Press **【DMX】** to save the setting and exit.

If partition function is turned off, the zone number of DS808A is a single number rather than multiple ones. Please refer 3-2 to set the zone of DS808A without partition function.

Appendix 1 Auto Off Table

A.o.00 Instant	A.o.01 1 sec.	A.o.02 2 sec.	A.o.03 3 sec.	A.o.04 4 sec.	A.o.05 5 sec.	A.o.06 6 sec.	A.o.07 7 sec.	A.o.08 8 sec.	A.o.09 9 sec.
A.o.10 10 sec	A.o.11 11 sec.	A.o.12 12 sec.	A.o.13 13 sec.	A.o.14 14 sec.	A.o.15 15 sec.	A.o.16 16 sec.	A.o.17 17 sec.	A.o.18 18 sec.	A.o.19 19 sec.
A.o.20 20 sec	A.o.21 21 sec.	A.o.22 22 sec.	A.o.23 23 sec.	A.o.24 24 sec.	A.o.25 25 sec.	A.o.26 26 sec.	A.o.27 27 sec.	A.o.28 28 sec.	A.o.29 29 sec.
A.o.30 30 sec	A.o.31 31 sec.	A.o.32 32 sec.	A.o.33 33 sec.	A.o.34 34sec.	A.o.35 35 sec.	A.o.36 36 sec.	A.o.37 37sec.	A.o.38 38sec.	A.o.39 39 sec.
A.o.40 40 sec	A.o.41 41 sec.	A.o.42 42 sec.	A.o.43 43 sec.	A.o.44 44sec.	A.o.45 45 sec.	A.o.46 46 sec.	A.o.47 47sec.	A.o.48 48sec.	A.o.49 49 sec.
A.o.50 50 sec	A.o.51 51 sec.	A.o.52 52 sec.	A.o.53 53 sec.	A.o.54 54sec.	A.o.55 55 sec.	A.o.56 56 sec.	A.o.57 57sec.	A.o.58 58sec.	A.o.59 59 sec.
A.o.60 60 sec	A.o.61 61 sec.	A.o.62 62 sec.	A.o.63 63 sec.	A.o.64 64sec.	A.o.65 65 sec.	A.o.66 66 sec.	A.o.67 67sec.	A.o.68 68sec.	A.o.69 69 sec.
A.o.70 70 sec	A.o.71 71 sec.	A.o.72 72 sec.	A.o.73 73 sec.	A.o.74 74sec.	A.o.75 75 sec.	A.o.76 76 sec.	A.o.77 77sec.	A.o.78 78sec.	A.o.79 79 sec.
A.o.80 80 sec	A.o.81 81 sec.	A.o.82 82 sec.	A.o.83 83 sec.	A.o.84 84sec.	A.o.85 85 sec.	A.o.86 86 sec.	A.o.87 87sec.	A.o.88 88sec.	A.o.89 89 sec.
A.o.90 90 sec	A.o.91 91 sec.	A.o.92 92 sec.	A.o.93 93 sec.	A.o.94 94 sec.	A.o.95 95 sec.	A.o.96 96 sec.	A.o.97 97sec.	A.o.98 98sec.	A.o.99 99 sec.

Appendix 2: Fader Time Table

0.1	0.2	0.3	0.4	0.5	0.6	0.7	0.8	0.9	1
0.1 s	0.2 s	0.3 s	0.4 s	0.5 s	0.6 s	0.7 s	0.8 s	0.9 s	1 s
2	3	4	5	6	7	8	9	10	12
2 s	3 s	4 s	5 s	6 s	7 s	8 s	9 s	10 s	12 s
14	16	18	20	25	30	35	40	45	50
14 s	16 s	18 s	20 s	25 s	30 s	35 s	40 s	45 s	50 s
55	1 ·	2 ·	3 ·	4 ·	5 ·	6 ·	7 ·	8 ·	9 ·
55 s	1 m	2 m	3 m	4 m	5 m	6 m	7 m	8 m	9 m
10 ·	11 ·	12 ·	13 ·	14 ·	15 ·	16 ·	17 ·	18 ·	19 ·
10 m	11 m	12 m	13 m	14 m	15 m	16 m	17 m	18 m	19 m
20 ·	21 ·	22 ·	23 ·	24 ·	25 ·	26 ·	27 ·	28 ·	29 ·
20 m	21 m	22 m	23 m	24 m	25 m	26 m	27 m	28 m	29 m
30 ·	31 ·	32 ·	33 ·	34 ·	35 ·	36 ·	37 ·	38 ·	39 ·
30 m	31 m	32 m	33 m	34 m	35 m	36 m	37 m	38 m	39 m
40 ·	41 ·	42 ·	43 ·	44 ·	45 ·	46 ·	47 ·	48 ·	49 ·
40 m	41 m	42 m	43 m	44 m	45 m	46 m	47 m	48 m	49 m
50 ·	51 ·	52 ·	53 ·	54 ·	55 ·	56 ·	57 ·	58 ·	59 ·
50 m	51 m	52 m	53 m	54 m	55 m	56 m	57 m	58 m	59 m
60 ·	61 ·	62 ·	63 ·	64 ·	65 ·	66 ·	67 ·	68 ·	69 ·
60 m	61 m	62 m	63 m	64 m	65 m	66 m	67 m	68 m	69 m
70 ·	71 ·	72 ·	73 ·	74 ·	75 ·	76 ·	77 ·	78 ·	79 ·
70 m	71 m	72 m	73 m	74 m	75 m	76 m	77 m	78 m	79 m
80 ·	81 ·	82 ·	83 ·	84 ·	85 ·	86 ·	87 ·	88 ·	89 ·
80 m	81 m	82 m	83 m	84 m	85 m	86 m	87 m	88 m	89 m
90 ·	91 ·	92 ·	93 ·	94 ·	95 ·	96 ·	97 ·	98 ·	99 ·
90 m	91 m	92 m	93 m	94 m	95 m	96 m	97 m	98 m	99 m